

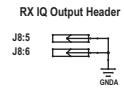

**CML Microcircuits**

*COMMUNICATION SEMICONDUCTORS*

# **High Resolution Circuit Diagrams for EV9720 March 2013**

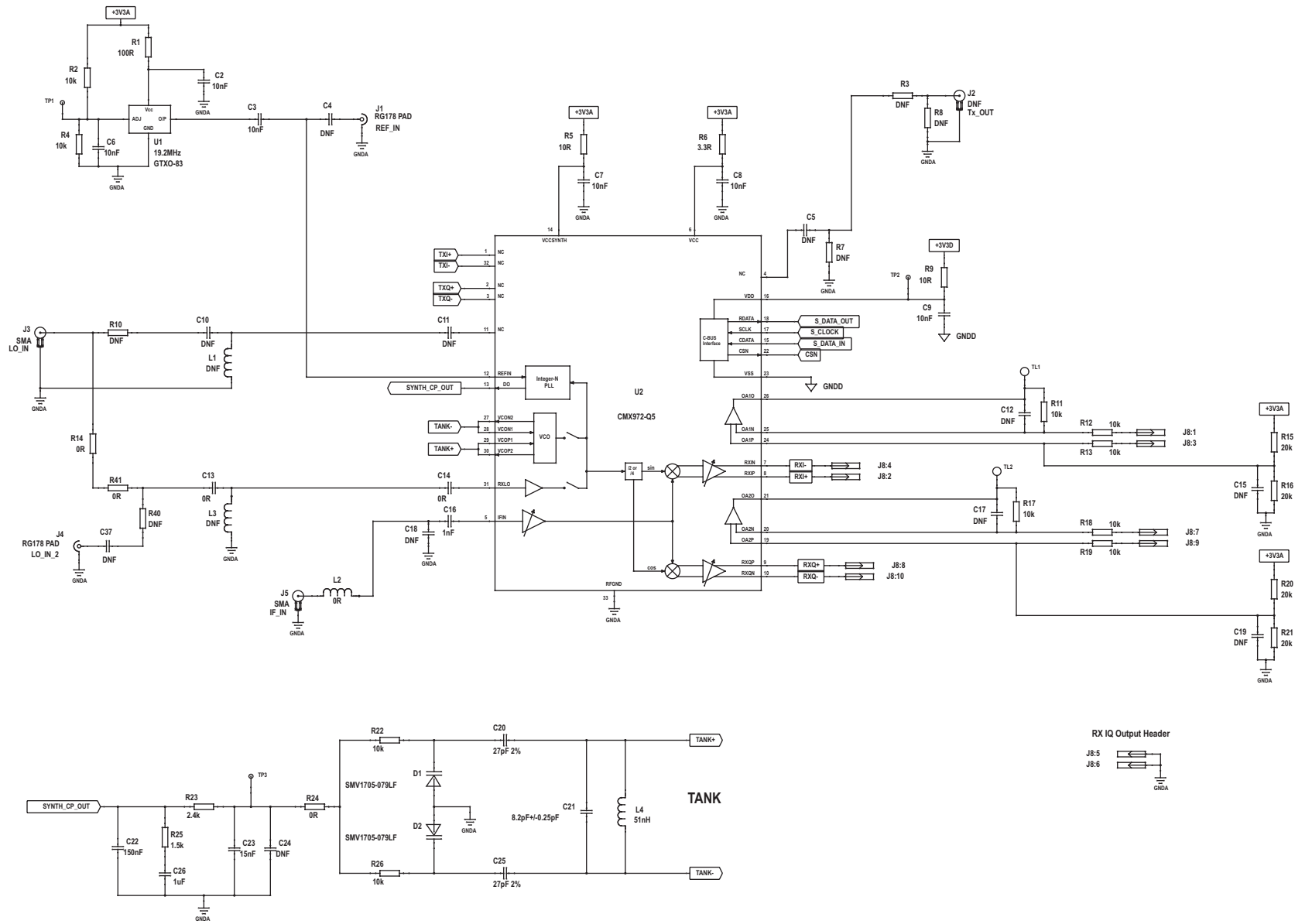

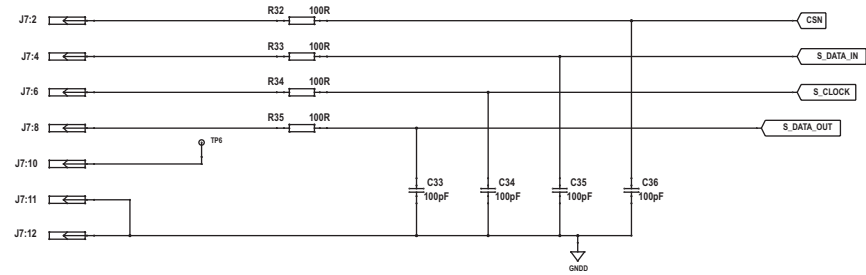
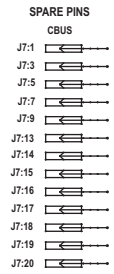

- J9 connections**
- Pin 2 TXI+
  - Pin 4 TXI-
  - Pin 5, 6 GNDA
  - Pin 8 TXQ+
  - Pin 10 TXQ-

